

Full-Bridge Power Amplifier

FEATURES

- Precision Current Control
- $\pm 800\text{mA}$ Load Current
- 1.25V Total V_{SAT} at 800mA
- Controlled Velocity Head Parking
- Precision Dual Supply Monitor with Indicator
- Limit Input to Force Output Extremes
- Inhibit Input and UVLO
- 4V to 15V operation

DESCRIPTION

This full-bridge power amplifier is rated for continuous output current of 0.8 Amperes and is intended for use in demanding servo applications such as head positioning for high-density disk drives. The device includes a precision current sense amplifier that provides accurate control of load current. Current is sensed with a single resistor in series with the load. The power amplifier has a very low output saturation voltage and will operate down to 4V supply levels. Power output stage protection includes current limiting and thermal shutdown.

Auxiliary functions on this device include a dual-input under-voltage comparator, which can monitor two independent supply voltages and force a built-in head park function when either is below minimum. When activated by either the UV comparator, or a command at the separate PARK input, the park circuitry will override the amplifier inputs to convert the power outputs to a programmable constant voltage source which will hold regulation as the supply voltage falls to below 3.0 Volts. Added features include a POWER OK flag output, a LIMIT input to force the drive output to its maximum level in either polarity, and a over-riding INHIBIT input to disable all amplifiers and reduce quiescent supply current.

This device is packaged in a power PLCC surface mount configuration which maintains a standard 28-pin outline, but with 7 pins along one edge allocated to ground for optimum thermal transfer. And is also available in a 24-pin surface mount SOIC package.

BLOCK DIAGRAM

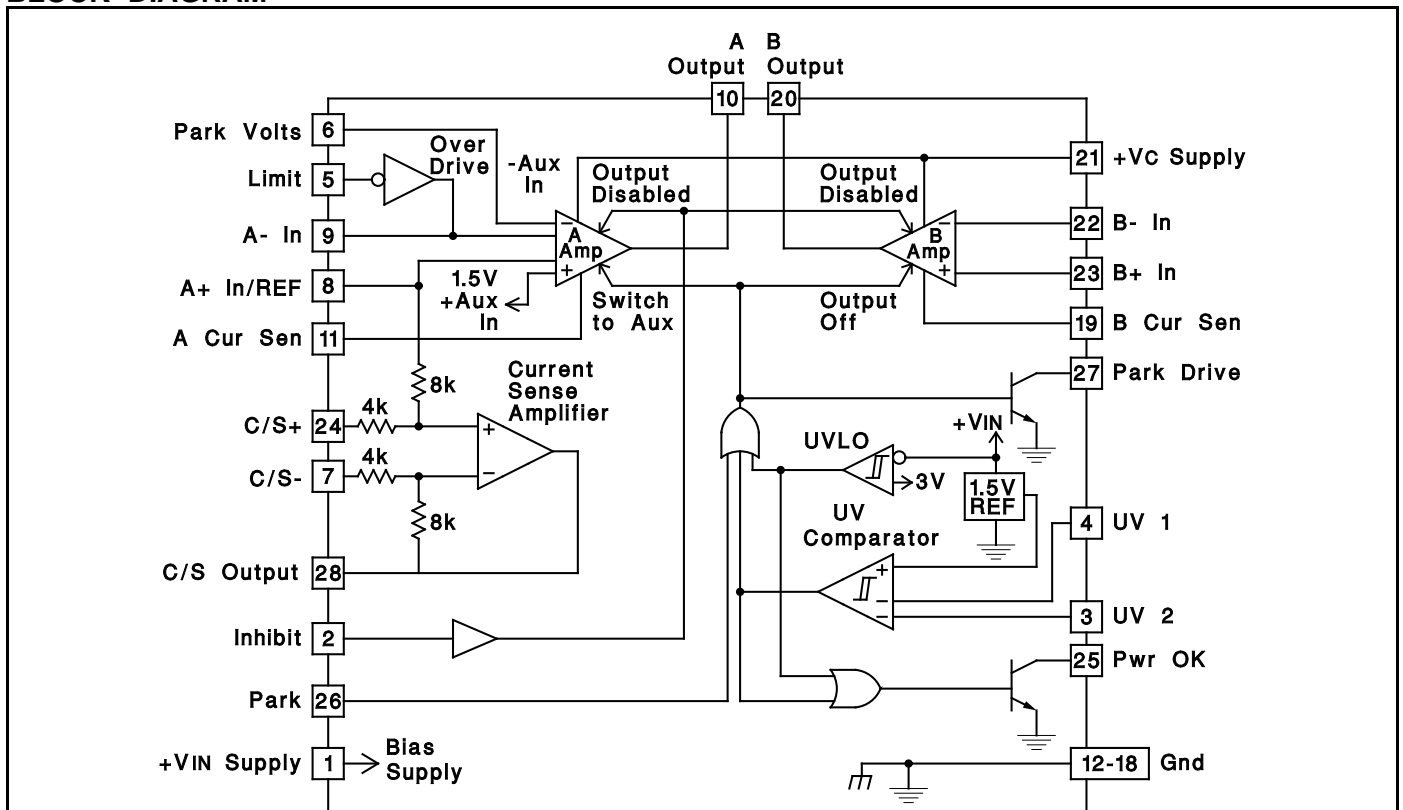

Note: Pin numbers refer to PLCC package.

UDG-92054-1

ABSOLUTE MAXIMUM RATINGS

Input Supply Voltage, (+VIN,+Vc).....	20V
UV Comparator, and Digital Inputs	
Maximum forced voltage.....	-0.3V to 10V
Maximum forced current.....	±10mA
C/S Inputs	
Maximum forced voltage.....	-0.3V to 20V
A and B Amplifier Inputs.....	-0.3V to +VIN
Open Collector Output Voltages.....	20V
A and B Output Currents (continuous)	
Source.....	Internally Limited
Sink.....	1.0A
Parking Drive Output Current	
Continuous.....	150mA
Pulsed.....	1A
Output Diode Current (pulsed).....	1A
Power OK Output Current(continuous).....	30mA
Operating Junction Temperature.....	-55°C to +150°C
Storage Temperature.....	-65°C to +150°C

Note 1: Unless otherwise indicated, voltages are referenced to ground and currents are positive into, negative out of, the specified terminals. "Pulsed" is defined as a less than 10% duty cycle pulse with a maximum duration of 500µs.
 Note 2: See Unitrode Integrated Circuits databook for information regarding thermal specifications and limitations of packages.

Thermal Data

QP Package:

Thermal Resistance Junction to Leads, θJL.....	15°C/W
Thermal Resistance Junction to Ambient, θJA.....	40°C/W

CONNECTION DIAGRAMS

**SOIC-24 (Top View)
DW Package**

**PLCC-28 (Top View)
QP Package**

PACKAGE PIN FUNCTION	
FUNCTION	PIN
+VIN	1
INH	2
UV2	3
UV1	4
Limit	5
Park Volts	6
C/S-	7
A+/REF Input	8
A- In	9
A Output	10
A Cur Sen	11
Gnd (Heat Dissipation Pins)	12-18
B Cur Sen	19
B Output	20
+Vc Supply	21
B- In	22
B+ In	23
C/S+	24
Pwr OK	25
Park	26
Park Drive	27
C/S Out	28

ELECTRICAL CHARACTERISTICS: Unless otherwise stated specifications apply for 0°C ≤ TA ≤ 70°C, +VIN = 12V, +Vc = +VIN, A+/REF Input = 6V. TA=TJ.

PARAMETER	TEST CONDITIONS	MIN	TYP	MAX	UNITS
INPUT SUPPLY					
+VIN Supply Current	All Amplifier Outputs = 6V		35	42	mA
+Vc Supply Current	IOUT = 0A		1		mA
+VIN UVLO Threshold	Low to High		2.8	3.0	V
UVLO Threshold Hysteresis			200		mV

ELECTRICAL CHARACTERISTICS (cont.)

Unless otherwise stated specifications apply for $0^{\circ}\text{C} \leq T_A \leq 70^{\circ}\text{C}$, $+V_{IN} = 12\text{V}$, $+V_C = +V_{IN}$, $A+/\text{REF INPUT} = 6\text{V}$. $T_A = T_J$.

PARAMETER	TEST CONDITIONS	MIN	TYP	MAX	UNITS
UNDER VOLTAGE (UV) COMPARATOR					
Input Bias Current		-1.5	-0.5		μA
UV Thresholds	Low to High, Other Input = 5V	1.48	1.50	1.52	V
UV Threshold Hysteresis		15	25	40	mV
Pwr OK V_{SAT}	$I_{OUT} = 5\text{mA}$			0.45	V
Pwr OK Leakage	$V_{OUT} = 20\text{V}$			5	μA
POWER AMPLIFIERS A and B					
Input Offset Voltage	$V_{CM} = 6\text{V}$, A Amplifier			8	mV
	B Amplifier			12	mV
Input Offset Drift	Note 1, A Amplifier Only			25	$\mu\text{V}/^{\circ}\text{C}$
Input Bias Current	$V_{CM} = 6\text{V}$, except A+/ REF Input	-500	-150		nA
Input Offset Current	$V_{CM} = 6\text{V}$, B Amplifier Only			200	nA
Input Bias Current at A+/ Ref Input	(A+/ Ref -C/S+)/12k, $T_J = 25^{\circ}\text{C}$	60	84	105	$\mu\text{A}/\text{V}$
CMRR	$1\text{V} \leq V_{CM} \leq 10\text{V}$	70	90		dB
PSRR	$+V_{IN} = 4\text{V}$ to 15V , $V_{CM} = 1.5\text{V}$	70	90		dB
Large Signal Voltage Gain	$V_{OUT} = 1\text{V}$, Sinking 500mA to $V_{OUT} = 11\text{V}$, Sourcing 500mA	3.0	15.0		V/mV
Slew Rate	1 to 13V, 13 to 1V, $T_J = 25^{\circ}\text{C}$		1	2.1	V/ μs
Unity Gain Bandwidth	Note 1, A Amplifier		2		MHz
	Note 1, B Amplifier		1		MHz
High-Side Current Limit		0.8	1.0		A
Output Saturation Voltage	High-Side, $I_{SOURCE} = 250\text{mA}$		0.7		V
	High-Side, $I_{SOURCE} = 800\text{mA}$		0.85		V
	Low-Side, $I_{SINK} = 250\text{mA}$		0.3		V
	Low-Side, $I_{SINK} = 800\text{mA}$		0.4		V
	Total, $I_{OUT} = 250\text{mA}$		1.0	1.2	V
	Total, $I_{OUT} = 800\text{mA}$		1.25	1.6	V
High Side Diode V_F	$I_D = 800\text{mA}$, Inhibit Activated		1.0		V
Low Side Diode V_F	$I_D = 800\text{mA}$, Inhibit Activated		1.0		V
CURRENT SENSE AMPLIFIER					
Input Offset Voltage	$V_{CM} = 6\text{V}$			2.0	mV
Input Offset Change with Common Mode Input	$0\text{V} \leq V_{CM} \leq 12\text{V}$			1500	$\mu\text{V}/\text{V}$
Input Offset Drift	Note 1			8	$\mu\text{V}/^{\circ}\text{C}$
Voltage Gain	$-1.0\text{V} \leq V_{DIFF} \leq +1.0\text{V}$, $V_{CM} = 6\text{V}$	1.95	2.00	2.05	V
Output Saturation Voltage	Low-Side, $I_{SINK} = 1.5\text{mA}$		0.3	0.5	V
	High-Side, $I_{SOURCE} = 1.5\text{mA}$		0.4	0.7	V
Maximum A+/ Ref Input	Volts Below $+V_{IN}$, C/S+ & C/S- = B_{OUTPUT} Max @ 10mA Output Current, $+V_{IN} = 4.5\text{V}$, C/S $V_{IO} \leq 5\text{mV}$		2.6	3.0	V
PARKING FUNCTION					
Park Input Threshold		0.7	1.1	1.7	V
Park Input Current	Park Input = 1.7V		60	100	μA
Park Drive Saturation Voltage, PD_{VSAT}	$I_{SINK} = 100\text{mA}$		0.3	0.5	V
Parking Drive Leakage	$V_{OUT} = 20\text{V}$			100	μA
Amplifier A Aux Input Bias Current		-500	-150		nA

ELECTRICAL CHARACTERISTICS (cont.)

Unless otherwise stated specifications apply for 0°C ≤ TA ≤ 70°C, +VIN = 12V, +Vc = +VIN, A+/REF Input = 6V. TA=TJ.

PARAMETER	TEST CONDITIONS	MIN	TYP	MAX	UNITS
PARKING FUNCTIONS (cont.)					
Amplifier A Saturation Voltage, AHVSAT	ISOURCE = 50mA, +VIN = 3V		0.65	0.8	V
Regulating Voltage at Park Volts		1.47	1.50	1.53	V
Minimum Parking Supply Voltage	AHVSAT + PDVSAT ≤ 1.3V @ 50mA		1.7	1.9	V
AUXILIARY FUNCTIONS					
Limit Input Low Voltage	A Output Forced Low	0.7	0.8		V
Limit Input High Voltage	A Output Forced High		2.2	2.3	V
Limit Inactive		1.2		1.8	V
Limit Open Circuit Voltage		1.45	1.50	1.55	V
Limit Input Resistance	1.2V ≤ Limit Input ≤ 1.8V		10		kΩ
Inhibit Input Threshold		0.7	1.1	1.7	V
Inhibit Input Current	Inhibit Input = 1.7V		400	700	μA
Supply Current when Inhibited	The sum of +VIN and +Vc currents		2	6	mA
Thermal Shutdown Temperature			165		°C

Note 1: This specification not tested in production.

UC3175B Series Current Sensing

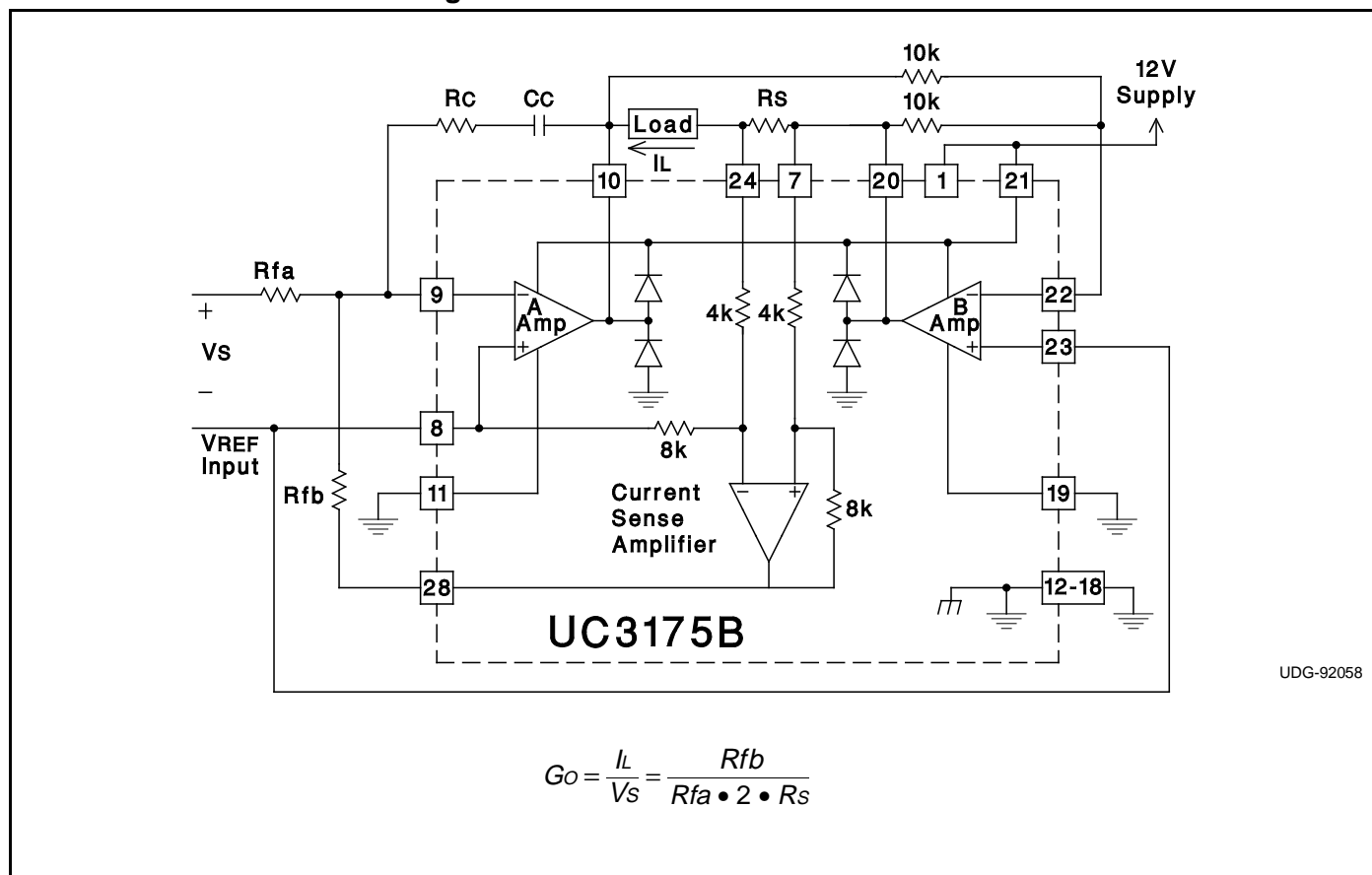

UDG-92058

Parking Function

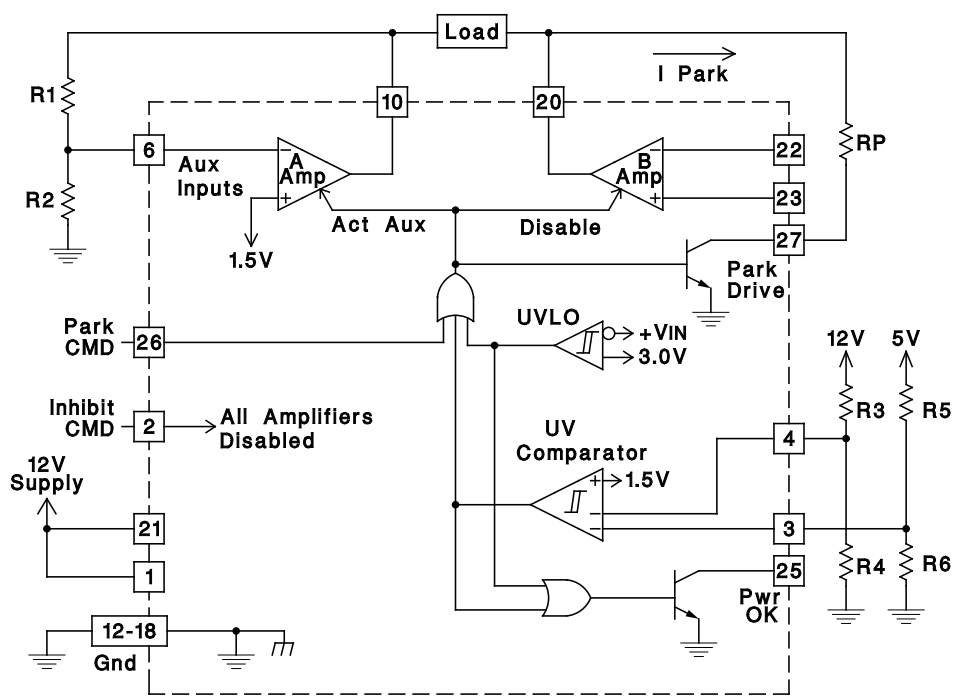

UDG-92059

Notes:
$$\text{Parking voltage} = \frac{1.5V \cdot R1 + R2}{R2 - (IL \cdot RP)}$$

RP is optional for current limiting.
Inhibit and Park Inputs are active high.
Pwr OK is low on power failure.